

OPTIONS

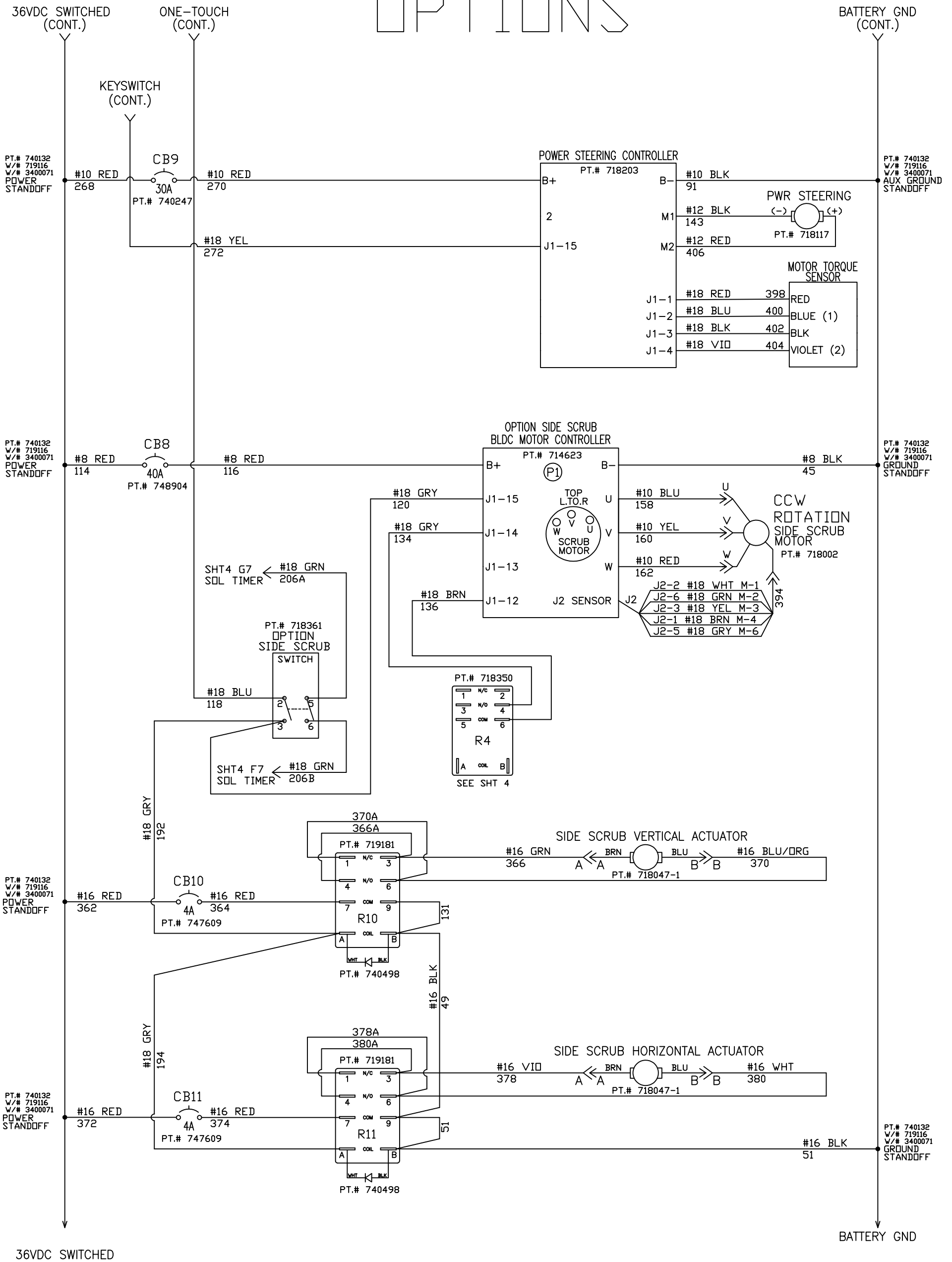

CONFIDENTIAL			
THIS DRAWING AND ALL INFORMATION CONTAINED THEREIN ARE THE EXCLUSIVE PROPERTY OF MINUTEMAN INTERNATIONAL, INC. THIS DRAWING IS NOT TO BE COPIED OR OTHERWISE REPRODUCED WITHOUT EXPRESSED WRITTEN PERMISSION OF MINUTEMAN INTERNATIONAL, INC. IN ADDITION, THIS DRAWING MUST BE RETURNED UPON REQUEST. FURTHER, ALL INFORMATION CONTAINED HEREIN MUST BE MAINTAINED CONFIDENTIAL.			
TITLE SCHEMATIC, SCRUBMASTER CYLINDRICAL			SCALE NTS
MATERIAL N/A		FINISH N/A	
TOLERANCES (UNLESS OTHERWISE SPECIFIED)		REMOVE BURRS AND BREAK SHARP EDGES .005/.020	
0-1" ± 1/16	.000 ± .005	SIZE B	DRAWN BY KEN.HARTLEY
>1-12" ± 1/4"	.00 ± .010	CHECKED BY KEN.HARTLEY	DATE 02/29/20
<12" ± 1/2"	ANGLES ± 30'		DATE 02/29/20
14N845 U.S. ROUTE 20 PINGREE GROVE, IL 60140		P.N. 719551 SHEET 5 OF 5	
REV	E.C.N.	DATE	CHANGE
			BY
			CHK BY